

AT840 Quick Start Guide

Version 1.0

2013-01-15

1. Installation and access.....	3
Ø Installation.....	3
Ø Feet installation instruction.....	3
Ø Check IP.....	5
Ø Login to AT840's webpage.....	5
2. Configure AT840 to make VoIP calls.....	6
Ø Network.....	6
Ø Set password.....	6
Ø SIP Settings.....	7

1. Installation and access

➤ Installation

Set up AT840 as below:

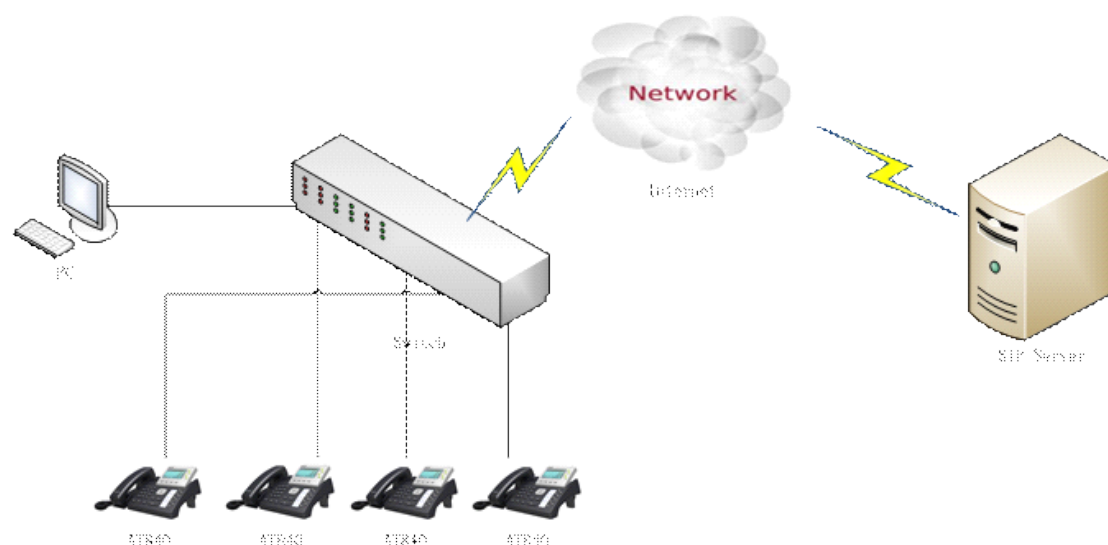

➤ Feet installation instruction

1) Desktop position:

A. Put the bottom side of the IP phone upside and press the plate with letter "PUSH" into the slot, please refer the picture as below:

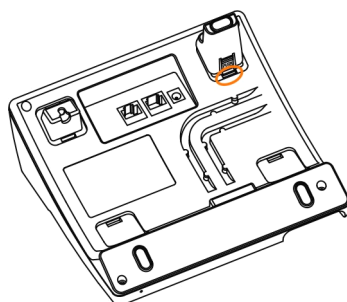

B. Press the other plate into the slot in accordance with the direction of the arrow

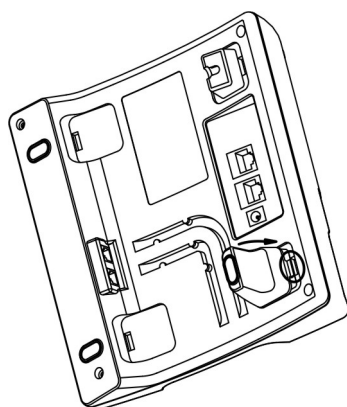

C. Repeat A and B. It is the right picture of putting on desk after fixing the

two feet below:

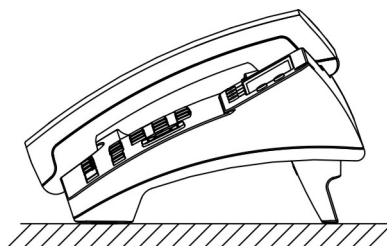

D. Disassemble the feet:

Press the plate with word "PUSH" and pull the feet with the direction of arrow. When the plate is pull out of the slot (there will be a sound of "pa") you can take off the feet

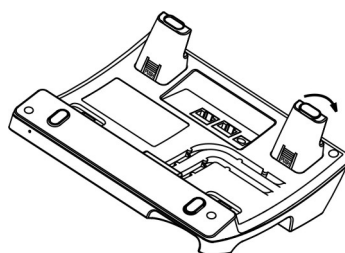

2) On wall position

A. Put the bottom side of the IP phone upside and push the plate with letter "PUSH" into the slot, please refer the picture as below:

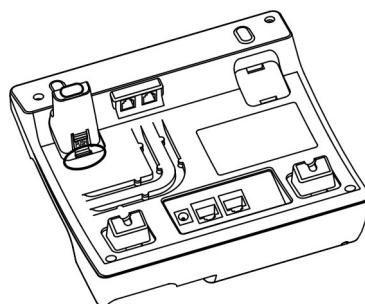

B. Push the other plate into the slot in accordance with the direction of the arrow

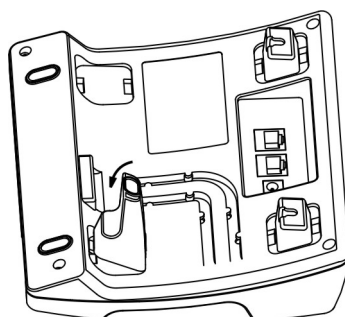

C. Repeat A and B. It is the picture of wall mounting after fixing the two feet below:

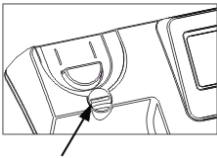
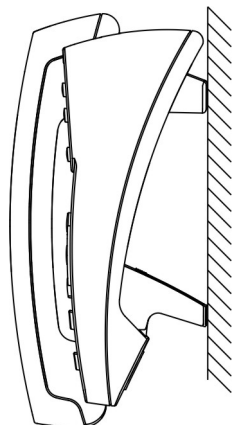

Attention: Please rotate the hook to the position as in picture with a coin or other tools

D. Disassemble the feet way:

Press the plate with word "PUSH" and pull the feet with the direction of arrow. When the plate is pull out of the slot (there will be a sound of "pa") you can take off the feet

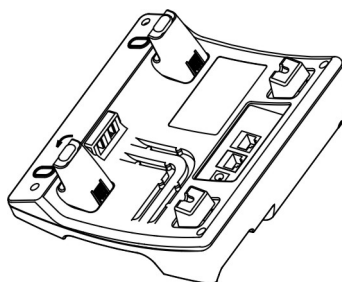

➤ **Check IP**

If AT840 is connect to your network. AT840 WAN default to use DHCP, and after connect WAN to Switch, it will obtain IP automatically. Press "Menu"-> "9.Network" you will see AT840's current IP.

➤ **Login to AT840's webpage**

Modify your computer's IP address to the same network as AT840. Enter AT840 IP addresses in the web browser to go to the login page, then you will access AT840's user webpage.

Click "admin" which is on the right corner to enter administrator webpage.

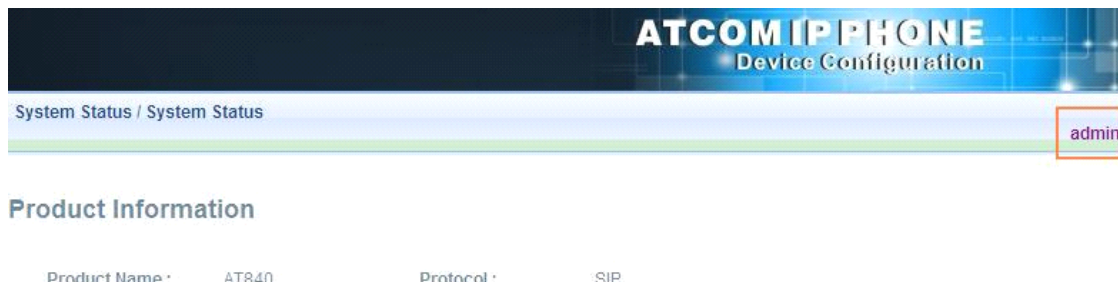

2. Configure AT840 to make VoIP calls

➤ Network

Enter "Network" -> "Basic" page.

There are 3 ways to connect to the internet DHCP, Static and PPPoE, please choose one according to your own situation.

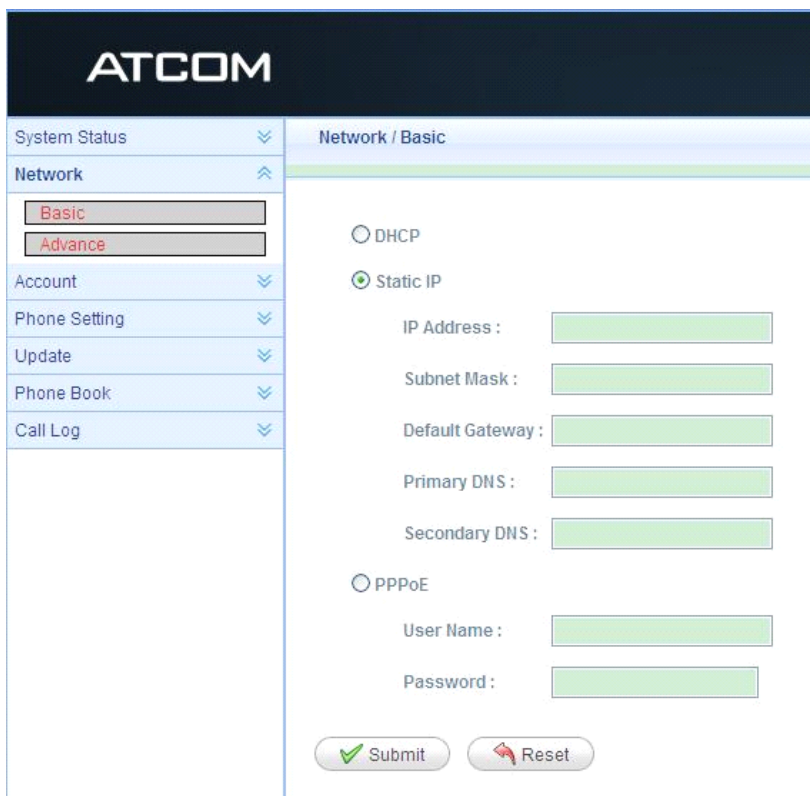

- ✓ Network mode: you can choose DHCP, Static and PPPoE
- ✓ DHCP: AT840 default to use DHCP to obtain dynamic IP.
- ✓ Static: If you want to set your ip as static, you should fill ip, netmask, gateway and DNS information.
- ✓ PPPoE: If connect AT840 to modem, you should fill ADSL account and the password which assigned by your network service provider.

➤ Set password

Enter "Network" -> "Advance" page.

There are 2 models to set the authority of web accessing and command line: User model and Admin model. All the parameters can be visible and changed in Admin mode while part of them can be visible in User mode.

System Status	Network / Advance
Network	
Basic	
Advance	
SIP Setting	
Account	
Phone Setting	
Update	
Phone Book	
Call Log	

Web Server	
Enable Web Server :	<input type="button" value="Yes"/>
Admin Password :	<input type="text"/> User Password : <input type="text"/>
HTTP Port :	<input type="text" value="80"/>
VPN	

- ✓ Enable Web Server: enable or disable web access. If choose "no", you can not access AT840 webpage.
- ✓ Admin password: set admin webpage access password.(username:admin)
- ✓ User password: set user webpage access password.(username:user)

➤ SIP Settings

Enter "Account" -> "SIP" page.

SIP

Enable :	<input type="button" value="Yes"/>
Display Name :	<input type="text" value="Phoebe"/> User ID : <input type="text" value="6001"/>
Authenticate ID :	<input type="text"/> Password : <input type="text" value="...."/>
SIP Server :	<input type="text" value="192.168.1.99"/> SIP Port : <input type="text" value="5060"/>
Use Outbound Proxy :	<input type="button" value="No"/>
Outbound Proxy Server :	<input type="text"/> Outbound Proxy Port : <input type="text" value="5060"/>
Register Expires :	<input type="text" value="300"/> Subscribe Expires : <input type="text" value="3600"/>
Transport Type :	<input type="button" value="UDP"/> SIP 100Rel Require : <input type="button" value="No"/>

- ✓ Enable: whether enable this sip register.
- ✓ Display Name: This name will display on your screen. It will show the User ID instead if leave display name as blank.
- ✓ User ID: Username of sip account.
- ✓ Authenticate ID: normally is the same with User ID, can also leave it as blank if there is no special requirement form your sip server.
- ✓ Password: Password of sip account.
- ✓ Sip Server: SIP server address , support both IP address and domain name.
- ✓ Sip Port: SIP server port , default is 5060.
- ✓ Use Outbound Proxy: Whether to use outbound proxy.
- ✓ Outbound Proxy Server: Normally the Proxy server is the same as SIP server. If they are different then fill in the correct information that provided by ISP.
- ✓ Outbound Proxy Port: Set your proxy server port.

- ✓ Register Expires: register expire time, default is 60 seconds. AT840 will auto configure this expire time to the server recommended setting if it is different from the SIP server.
- ✓ Subscribe Expires: The Expires value in SUBSCRIBE message, default is 3600 seconds.
- ✓ Transport Type: UDP/TCP/TLS.
- ✓ SIP 100Rel Require : Require 100rel or not, default is no. If set to yes, the INVITE message sent will contain the *require:100rel* header field.

After configured and enabled register this account, please check the status of this account in System Status page.

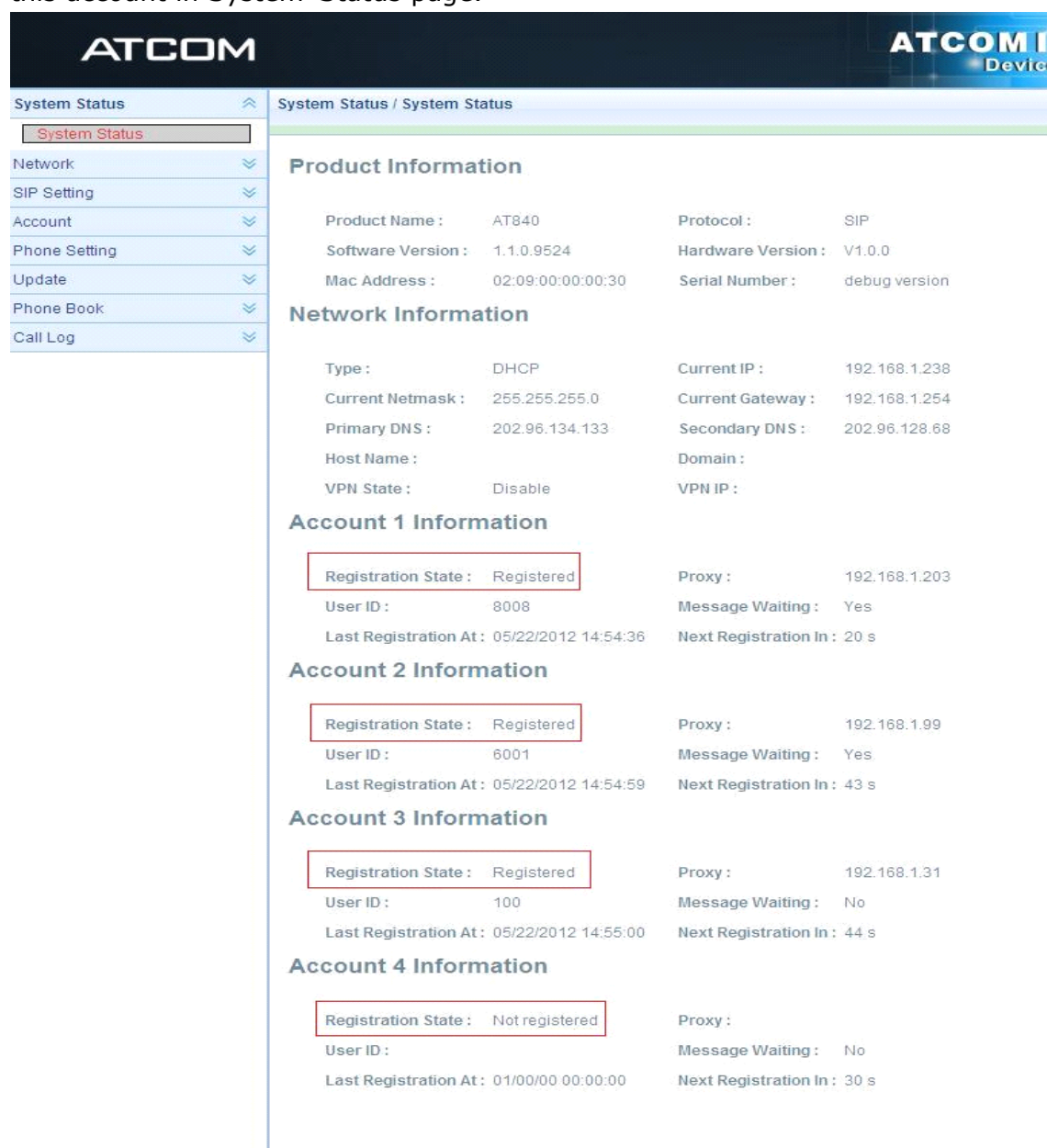

The screenshot shows the ATCOM Device System Status page. The left sidebar contains a navigation menu with the following items: System Status (selected), Network, SIP Setting, Account, Phone Setting, Update, Phone Book, and Call Log. The main content area is titled 'System Status / System Status' and is divided into several sections:

- Product Information:**
 - Product Name : AT840
 - Software Version : 1.1.0.9524
 - Mac Address : 02:09:00:00:00:30
 - Protocol : SIP
 - Hardware Version : V1.0.0
 - Serial Number : debug version
- Network Information:**
 - Type : DHCP
 - Current Netmask : 255.255.255.0
 - Primary DNS : 202.96.134.133
 - Host Name :
 - VPN State : Disable
 - Current IP : 192.168.1.238
 - Current Gateway : 192.168.1.254
 - Secondary DNS : 202.96.128.68
 - Domain :
 - VPN IP :
- Account 1 Information:**
 - Registration State : Registered
 - User ID : 8008
 - Last Registration At : 05/22/2012 14:54:36
 - Proxy : 192.168.1.203
 - Message Waiting : Yes
 - Next Registration In : 20 s
- Account 2 Information:**
 - Registration State : Registered
 - User ID : 6001
 - Last Registration At : 05/22/2012 14:54:59
 - Proxy : 192.168.1.99
 - Message Waiting : Yes
 - Next Registration In : 43 s
- Account 3 Information:**
 - Registration State : Registered
 - User ID : 100
 - Last Registration At : 05/22/2012 14:55:00
 - Proxy : 192.168.1.31
 - Message Waiting : No
 - Next Registration In : 44 s
- Account 4 Information:**
 - Registration State : Not registered
 - User ID :
 - Last Registration At : 01/00/00 00:00:00
 - Proxy :
 - Message Waiting : No
 - Next Registration In : 30 s